

## 3D Design and Modelling of E-Bike Braking and Suspension System

Kethavath Lakpathi<sup>1</sup>, V. Jaipal<sup>1</sup>, Shaik Sadiq Ali<sup>1</sup>

<sup>1</sup>Department of Mechanical Engineering, SreeDattha Institute of Engineering and Science, Hyderabad, India

### ABSTRACT

A brake is a mechanical device which inhibits motion. A drum brake is a brake that uses friction caused by a set of shoes or pads that press against a rotating drum-shaped part called a brake drum. The Suspension system is the most important part in any vehicle. It handles shock impulse and dissipates kinetic energy. It reduces the amplitude of disturbances and improved ride quality. In this paper, A two-wheeler suspension system is designed and modelled in 3D modelling software CATIA. Structural analysis is done on suspension system at different loads 175Kg, 250Kg and 325Kg. Modelling of drum brake and drum brake pads are done in CATIA design software. Thus both files are saved as igs to import into ANSYS workbench Structural analysis is carried on drum brake in ANSYS workbench First structural analysis of pressure of 1.5 Mpa is applied with three different materials such as cast iron, stainless Steel, aluminium alloy 7475.

Keywords:

### 1. INTRODUCTION

A drum brake is a brake that uses friction caused by a set of shoes or pads that press outward against a rotating cylinder-shaped part called a brake drum. The term drum brake usually means a brake in which shoes press on the inner surface of the drum. When shoes press on the outside of the drum, it is usually called a clasp brake. Where the drum is pinched between two shoes, like a conventional disc brake, it is sometimes called a pinch drum brake, though such brakes are relatively rare. A related type called a band brake uses a flexible belt or "band" wrapping around the outside of a drum.



Fig. 1: Drum brake.

**Drum Brake in Operation:** This is where it gets a little more complicated. Many drum brakes are self-actuating. Figure 1 shows that as the brake shoes contact the drum, there is a kind of wedging action, which has the effect of pressing the shoes into the drum with more force. The extra braking force provided by the wedging action allows drum brakes to use a smaller piston than disc brakes. Pneumatic and hydraulic shock absorbers are used in conjunction with cushions and springs. An automobile shock absorber contains spring-loaded check valves and orifices to control the flow of oil through an internal piston.

One design consideration, when designing or choosing a shock absorber, is where that energy will go. In most shock absorbers, energy is converted to heat inside the viscous fluid. In hydraulic cylinders, the hydraulic fluid heats up, while in air cylinders, the hot air is usually exhausted to the atmosphere. In other types of shock absorbers, such as electromagnetic types, the dissipated energy can be stored and used later. In general terms, shock absorbers help cushion vehicles on uneven roads.

## 2. MODELING AND ANALYSIS

Computer-aided design (CAD), also known as computer-aided design and drafting (CADD), is the use of computer technology for the process of design and design-documentation. Computer Aided Drafting describes the process of drafting with a computer. CADD software, or environments, provide the user with input-tools for the purpose of streamlining design processes, drafting, documentation, and manufacturing processes. CADD output is often in the form of electronic files for print or machining operations. The development of CADD-based software is in direct correlation with the processes it seeks to economize; industry-based software (construction, manufacturing, etc.) typically uses vector-based (linear) environments whereas graphic-based software utilizes raster-based (pixelated) environments.

CATIA is an acronym for Computer Aided Three-dimensional Interactive Application. It is one of the leading 3D software used by organizations in multiple industries ranging from aerospace, automobile to consumer products.

CATIA provides the capability to visualize designs in 3D. When it was introduced, this concept was innovative.

### 3D model

#### Assemble product

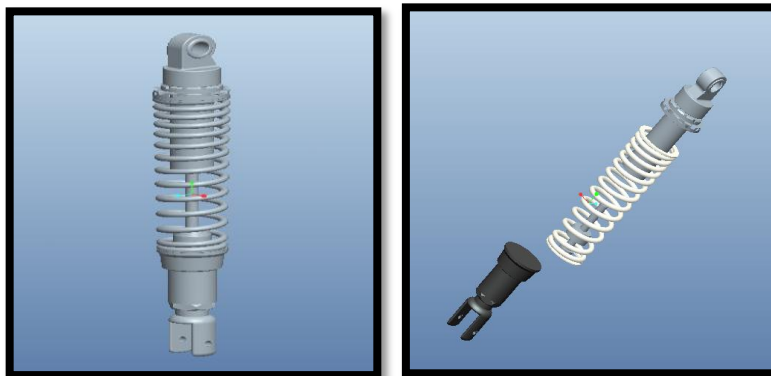

(a) (b)

Fig. 2:(a) Solid model of suspension system. (b) Exploded view of suspension system.

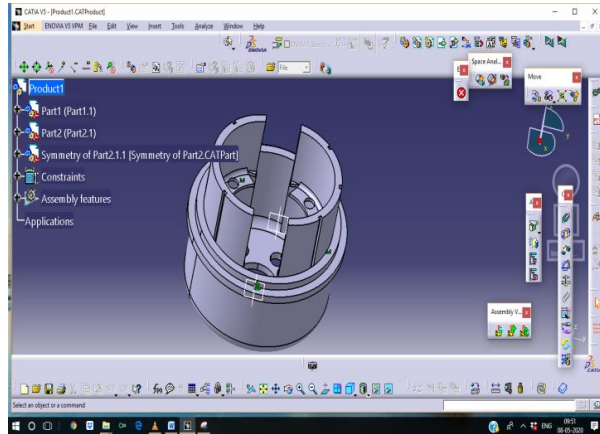

Fig. 3: Model of drum break.

### 3. RESULTS AND DISCUSSION

#### Static Analysis of Drum Brake

Imported model

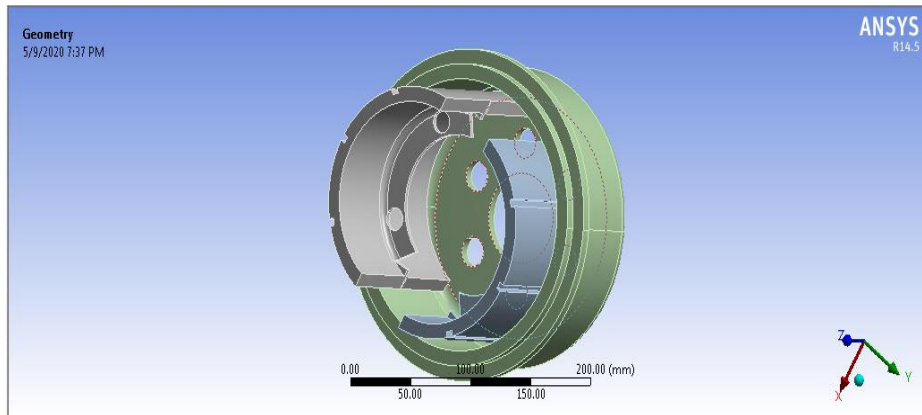

Fig. 4: Imported model form modelling software.

Meshed model

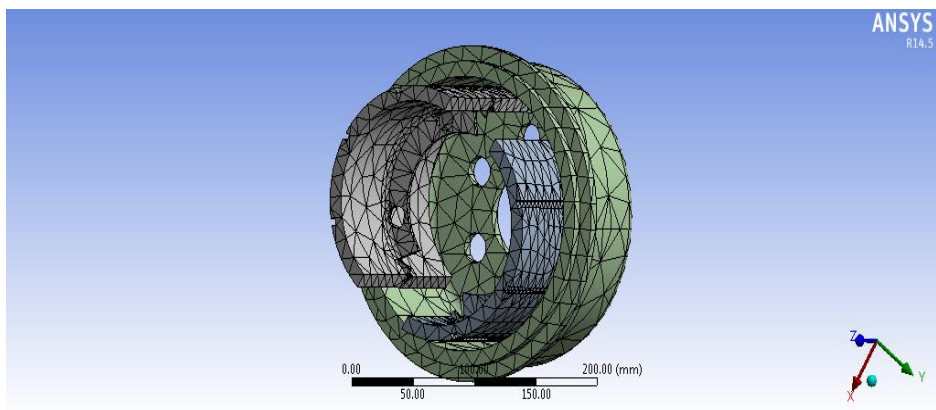

Fig.5: Meshing model.

According above figure shows divided by elements through fine meshing.

**Material-Aluminium Alloy**

**Total deformation**

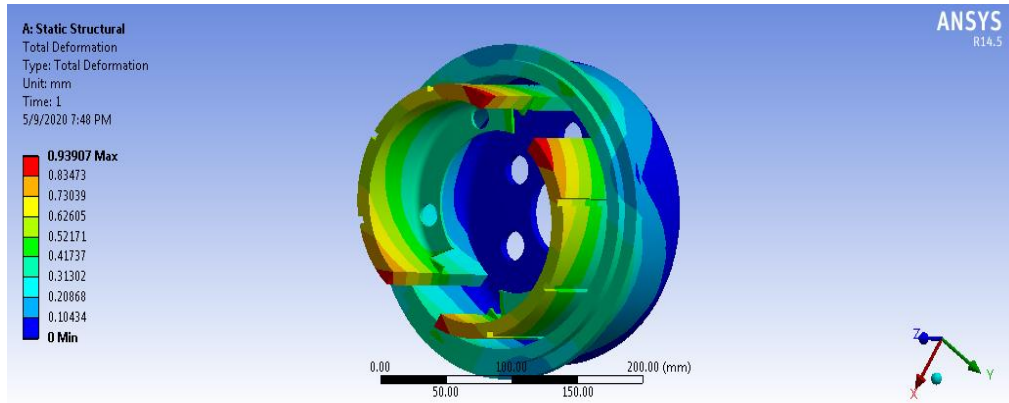

Fig. 6: Deformation.

**Equivalent stress**

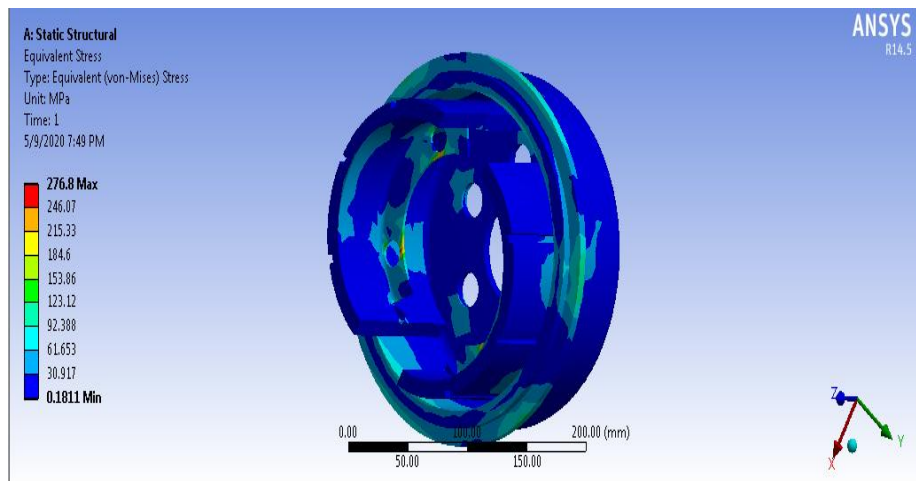
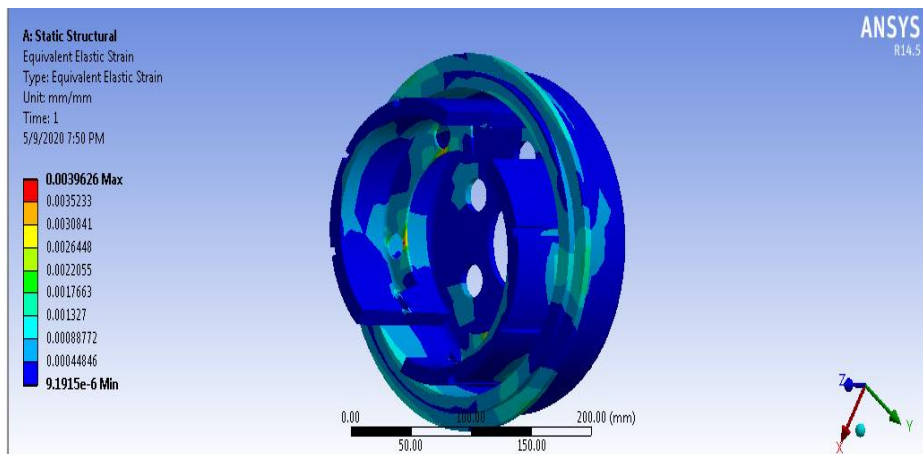

Fig. 7: Stress.

**Equivalent strain**



**Static Analysis of Suspension System**

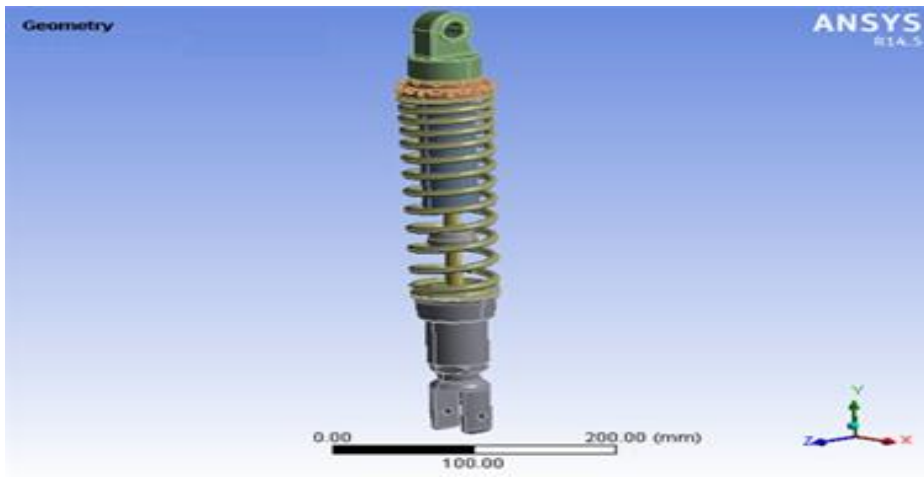
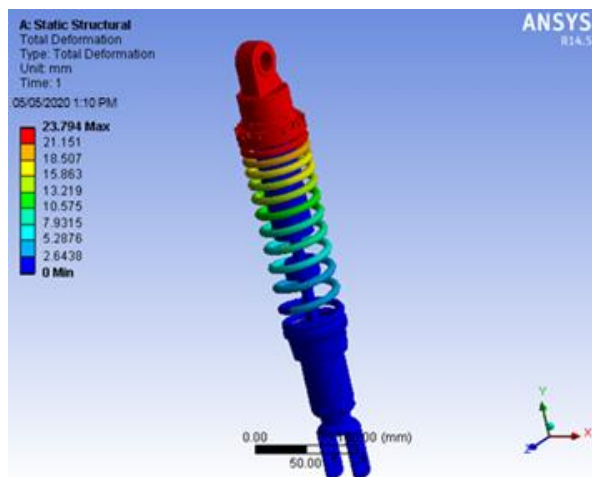
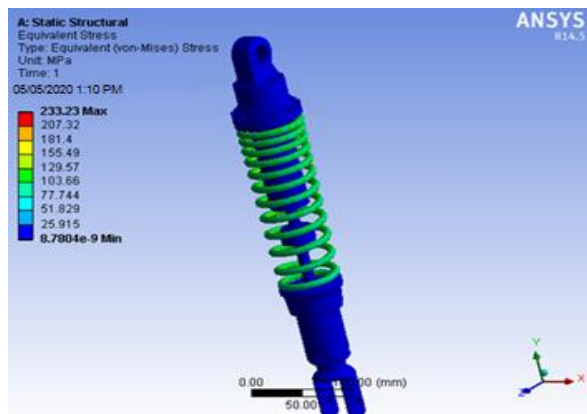

Fig. 8: Imported model.

**Total deformation**



**Stress**



**Strain**

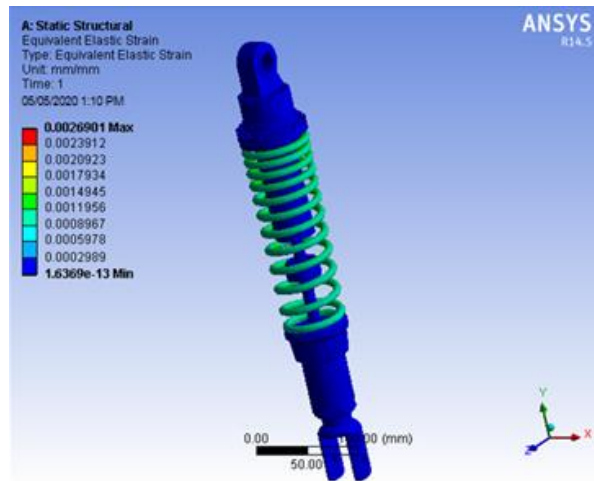

**Static Results of braking system**

Materials	Deformation (Mm)	Stress (N/Mm <sup>2</sup> )	Strain
Cast Iron	0.60938	282.5	0.0026102
Stainless Steel	0.34637	279.2	0.0014703
Aluminum Alloy	0.9907	276.8	0.003926

**Static Analysis Results of suspension system**

Load (Kgs)	Deformation (Mm)	Stress (N/Mm <sup>2</sup> )	Strain
175	23.794	273.23	0.0026901
250	22.74	377.89	0.0025092
325	31.875	529.68	0.003504

**Static analysis Graphs**

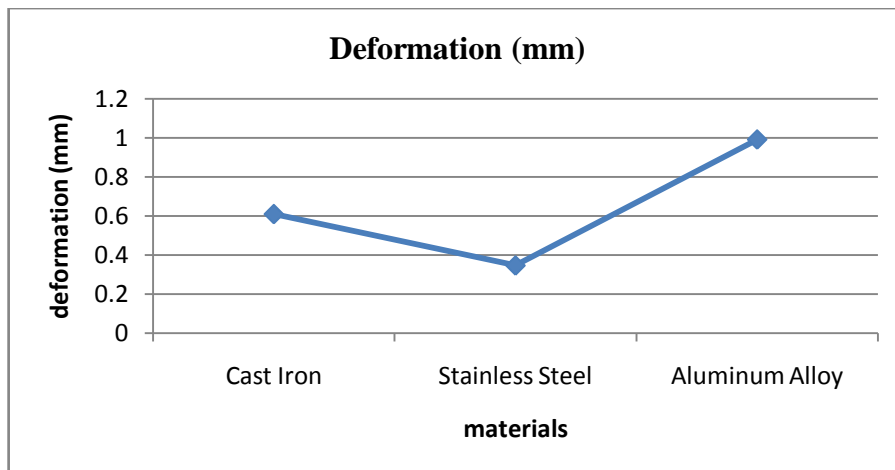

**Stress**

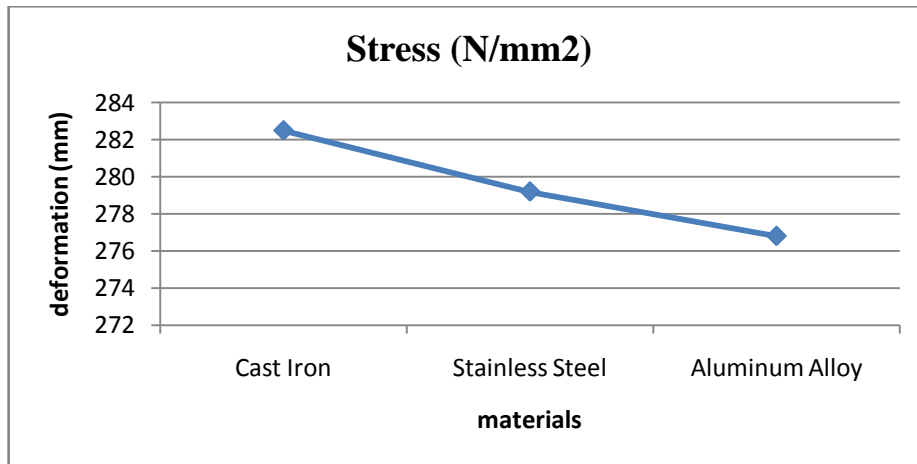

**4. CONCLUSION**

A two-wheeler suspension system is designed and modelled in 3D modelling software CATIA. Structural analysis is done on suspension system at different loads 175Kg, 250Kg and 325Kg. By observing the structural analysis results, the stress value is less for Single person load than other loads. Modelling of drum brake and drum brake pads are done in CATIA design software. Thus both files are saved as igs to import into ANSYS workbench Structural analysis is carried on drum brake in ANSYS workbench First structural analysis of pressure of 1.5 Mpa is applied with three different materials such as cast iron, stainless Steel, aluminum alloy 7475. By observing the structural analysis results, the stress value is less for aluminum alloy than other materials such as stainless steel and castiron.

**REFERENCES**

- [1] Christianah O. Ijagbemia, Bankole I. Oladapo, “Design and simulation of fatigue analysis for a vehicle suspension system (VSS) and its effect on global warming”, *Procedia Engineering*, 159 (2016) 124 – 132.
- [2] M. Venkatesan, “Design and analysis of composite leaf spring in light vehicle,” *I2OR*.
- [3] Mr. J. J. Pharne, “Design, analysis, and experimental validation for fatigue behavior of a helical compression spring used for a two-wheeler horn”, *International Journal of Mechanical and Industrial Engineering (IJMIE)*, vol. 2, no. 3, 2012.
- [4] Chandrakant Chavan, “Analysis for suspension spring to determine and improve its fatigue life using finite element methodology,” *International Journal of Engineering and Computer Science*, vol. 4, no. 3, Mar. 2015.
- [5] Tausif m. Mulla, sunil j. Kadam, vaibhav s. Kengar, “Finite element analysis of helical coil compression spring for three-wheeler automotive front suspension”, *International Journal of Mechanical and Industrial Engineering (IJMIE)*, vol. 2, no. 3, 2012.
- [6] Rajkumar V. Patil, “Comparison of cylindrical and conical helical springs for their Buckling load and deflection,” *International Journal of Mechanical and Industrial Engineering (IJMIE)* ISSN No. 2231 –6477, Vol-1, Iss-2, 2011.
- [7] B. D. Shiwalkar, “Design data for machine elements,” 2012 Edition, pp. 79-92.
- [8] R. S. Khurmi and J. K. Gupta, “Machine Design”, S. Chand publication, pp.820-844.