

Comprehensive Control Strategy for Wind Turbine Systems: Integrating Active Power Filtering, Power Quality Enhancement, and Grid Connection with PID and Conservative Power Theory Decompositions

I. Vidyasree¹, T. Bhavani¹, G. Aswini¹

¹Assistant Professor, Dept. of EEE, Malla Reddy Engineering College and Management Sciences, Medchal, Hyderabad, India

ABSTRACT

A comprehensive control of a wind turbine system connected to an industrial plant with PID is discussed in this project, where an algorithm has been developed allowing a control structure that utilizes a four-leg inverter connected to the grid side to inject the available energy as well as to work as an active power filter, mitigating load current disturbances and enhancing power quality. A four-wire system is considered with three-phase and single-phase linear and nonlinear loads. During the connection of the wind turbine, the utility side controller is designed to compensate for disturbances caused by reactive, non-linear, and/or unbalanced single- and intra-phase loads, in addition to providing active and reactive power as required. When there is no wind power available, the controller is intended to improve the power quality using the DC-link capacitor with the power converter attached to the grid. The main difference between the proposed methodology and others in the literature is that the proposed control structure is based on the Conservative Power Theory decompositions. This choice provides decoupled power and current references for the inverter control, offering very flexible, selective, and powerful functionalities. Real-time software benchmarking has been conducted in order to evaluate the performance of the proposed control algorithm for full real-time implementation. The control methodology is implemented and validated in hardware-in-the-loop (HIL) based on Opal-RT and a TI DSP. The control methodology is implemented and validated in MATLAB/SIMULINK. The results corroborated our power quality enhancement control and allowed us to exclude passive filters, contributing to a more compact, flexible, and reliable electronic implementation of a smart grid-based control.

Index Terms--Conservative power theory, Four-leg voltage source converter, Hardware-in-the-loop, Power quality, permanent magnet synchronous generator.

I. INTRODUCTION

The global capacity of installed wind turbines has rapidly increased in the last few years, by 2013 there were about 300 GW of installed wind capacity [1]. There have been tremendous developments in the wind turbine industry supporting this energy source as a mainstream renewable resource, with competitive costs in \$/kWh when compared to traditional fossil fuel power plants. This development is due to the advancement in electrical generators and power electronics. The main issue with renewable energy is that the power is not always available when it is needed. With the increase of power production of renewable resources, utility integration has been developed and implemented and power electronic inverters are used to control active/reactive power, frequency, and to support grid voltage during faults and voltage sags [2]-[4]. Several control approaches

have been introduced in the literature for wind turbine in standalone and grid connected systems [5], [6]. The machine side controllers are designed to extract maximum power point from wind using hill-climbing control, fuzzy-based, and adaptive controllers [7], most of the time based on field-oriented or vector control approach. The grid side controllers are designed to ensure active and reactive power is delivered to the grid [8], [9]. In order to allow the theoretical framework, different power theories have been proposed and implemented in electrical power systems to analyze current and voltage components, such as the instantaneous power (PQ) theory for a three-phase system made by Akagi [10]. In PQ theory, the three-phase is transformed into a two-phase reference frame in order to extract active and reactive components in a simplified manner. A three-phase power theory in a broader

perspective has been introduced, known as the Conservative Power Theory (CPT), where the current and voltage components are derived in the three-phase form, without requiring any reference-frame transformation. The performance of these theories has been compared in references. This paper proposes a control structure in three-phase four wire systems that provides more functionality to the grid side converter of a wind turbine system using the conservative power theory (CPT) as an alternative to generating different current references for selective disturbances compensation, where both single- and three- phase loads are fed. Three phase, four-wire inverters have been realized using conventional three-leg converters with “split-capacitor” or four-leg converters. In a three-leg conventional converter, the ac neutral wire is directly connected to the electrical midpoint of the DC bus. In four-leg converter, the ac neutral wire connection is provided through the fourth switch leg. The “four-leg” converter topology has better controllability than the “split-capacitor” converter topology. The considered system consists of single- and three-phase linear and nonlinear (balanced and unbalanced) loads. The CPT is used to identify and to quantify the amount of resistive, reactive, unbalanced and nonlinear characteristics of a particular load under different supply voltages condition for four-wire system.

II. POWER QUALITY

The contemporary container crane industry, like many other industry segments, is often enamored by the bells and whistles, colorful diagnostic displays, high speed performance, and levels of automation that can be achieved. Although these features and their indirectly related computer-based enhancements are key issues to an efficient terminal operation, we must not forget the foundation upon which we are building. Power quality is the mortar which bonds the foundation blocks. Power quality also affects terminal operating economics, crane reliability, our environment, and initial investment in power distribution systems to support new crane installations. To quote the utility company newsletter which accompanied the last monthly issue of my home utility billing: ‘Using electricity wisely is a good environmental and business practice which saves you money, reduces emissions from generating plants, and conserves our natural resources.’ As we are all aware, container crane performance requirements continue to increase at an astounding rate. Next generation container cranes, already in the bidding process, will require average power demands of 1500 to 2000 kW – almost double the total average demand three years ago. The rapid increase in power demand levels, an increase in container crane

population, SCR converter crane drive retrofits and the large AC and DC drives needed to power and control these cranes will increase awareness of the power quality issue in the very near future.

2.1. Power quality problems

For this article, we shall define power quality problems as: Any power problem that results in failure or disoperation of customer equipment, manifests itself as an economic burden to the user, or produces negative impacts on the environment. When applied to the container crane industry, the power issues which degrade power quality include:

- Power Factor
- Harmonic Distortion
- Voltage Transients
- Voltage Sags or Dips
- Voltage Swells

The AC and DC variable speed drives utilized on board container cranes are significant contributors to total harmonic current and voltage distortion. Whereas SCR phase control creates the desirable average power factor, DC SCR drives operate at less than this. In addition, line notching occurs when SCR’s commutate, creating transient peak recovery voltages that can be 3 to 4 times the nominal line voltage depending upon the system impedance and the size of the drives. The frequency and severity of these power system disturbances varies with the speed of the drive. Harmonic current injection by AC and DC drives will be highest when the drives are operating at slow speeds. Power factor will be lowest when DC drives are operating at slow speeds or during initial acceleration and deceleration periods, increasing to its maximum value when the SCR’s are phased on to produce rated or base speed. Above base speed, the power factor essentially remains constant. Unfortunately, container cranes can spend considerable time at low speeds as the operator attempts to spot and land containers. Poor power factor places a greater kVA demand burden on the utility or engine-alternator power source. Low power factor loads can also affect the voltage stability which can ultimately result in detrimental effects on the life of sensitive electronic equipment or even intermittent malfunction. Voltage transients created by DC drive SCR line notching, AC drive voltage chopping, and high frequency harmonic voltages and currents are all significant sources of noise and disturbance to sensitive electronic equipment. It has been our experience that end users often do not associate power quality problems with Container cranes, either

because they are totally unaware of such issues or there was no economic Consequence if power quality was not addressed. Before the advent of solid-state power supplies, Power factor was reasonable, and harmonic current injection was minimal. Not until the crane Population multiplied, power demands per crane increased, and static power conversion became the way of life, did power quality issues begin to emerge. Even as harmonic distortion and power Factor issues surfaced, no one was really prepared. Even today, crane builders and electrical drive System vendors avoid the issue during competitive bidding for new cranes. Rather than focus on Awareness and understanding of the potential issues, the power quality issue is intentionally or unintentionally ignored. Power quality problem solutions are available. Although the solutions are not free, in most cases, they do represent a good return on investment. However, if power quality is not specified, it most likely will not be delivered. Power quality can be improved through:

- Power factor correction,
- Harmonic filtering,
- Special line notch filtering,
- Transient voltage surge suppression,
- Proper earthing systems.

In most cases, the person specifying and/or buying a container crane may not be fully aware of the potential power quality issues. If this article accomplishes nothing else, we would hope to provide that awareness. In many cases, those involved with specification and procurement of container cranes may not be cognizant of such issues, do not pay the utility billings, or consider it someone else's concern. As a result, container crane specifications may not include definitive power quality criteria such as power factor correction and/or harmonic filtering. Also, many of those specifications which do require power quality equipment do not properly define the criteria.

III. PID CONTROL

PID can be described as a set of rules with which precise regulation of a closed loop control system is obtained. Closed loop control means a method in which a real-time measurement of the process being controlled is constantly fed back to the controlling device to ensure that the value which is desired is, in fact, being realized. The mission of the controlling device is to make the measured value, usually known as the "process variable", equal to the desired value, usually known as the setpoint. The very best way of accomplishing this task is with the use of the control algorithm we know as PID. In its basic form, PID involves three mathematical control functions working together is Proportional Integral Derivative. The most important of these, Proportional Control, determines the magnitude of the difference between the setpoint and the process

variable (known as error), and then applies appropriate proportional changes to the control variable to eliminate error. Many control systems will, in fact, work quite well with only Proportional Control. Integral Control examines the offset of setpoint and the process variable over time and corrects it when and if necessary. Derivative Control monitors the rate of change of the process variable and consequently makes changes to the output variable to accommodate unusual changes. Each of the three control functions is governed by a user defined parameter. These parameters vary immensely from one control system to another, and, as such, need to be adjusted to optimize the precision of control. The process of determining the values of these parameters is known as PID Tuning. PID Tuning, although considered "black magic" by many, really is, of course, always a well-defined technical process.

There are several different methods of PID Tuning available, any of which will tune any system. Certain PID Tuning methods require more equipment than others, but usually result in more accurate results with less effort. The P stands for proportional control, I for integral control and D for derivative control. This is also what is called a three-term controller. The basic function of a controller is to execute an algorithm (electronic controller) based on the control engineer's input (tuning constants), the operators desired operating value (set point) and the current plant process value. In most cases, the requirement is for the controller to act so that the process value is as close to the set point as possible. In a basic process control loop, the control engineer utilizes the PID algorithms to achieve this.

3.1. Controlling of PID

The PID controller's job is to maintain the output at a level so that there is no difference (error) between the process variable (Pv) and the setpoint (SP).

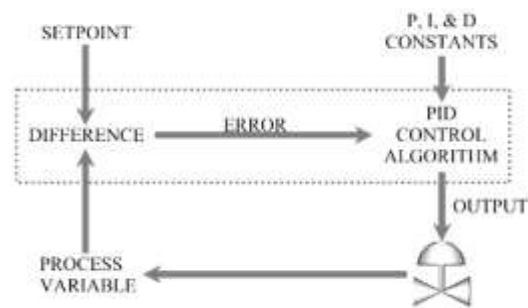

Fig.1 PID working module

In the diagram shown above the valve could be controlling the gas going to a heater, the chilling of a cooler, the pressure in a pipe, the flow through a pipe, the level in a tank, or any other process control system.

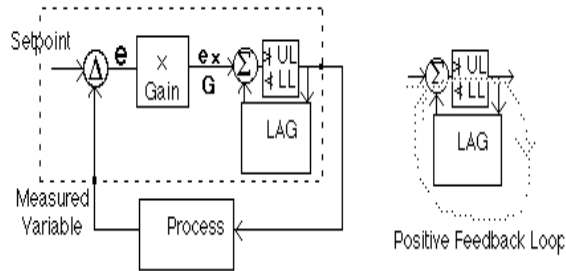

Fig.2 Integral mode implementation

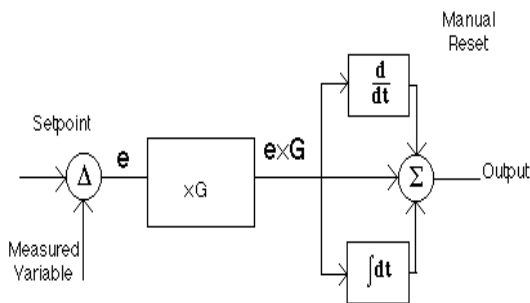

Fig3. Block diagram of PID controller

The equation for the derivative contribution (assuming derivative on error) is:

$$Out = g \times K_d \times de/dt$$

IV. WIND POWER

Offshore wind power refers to the construction of wind farms in bodies of water to generate electricity from wind. Unlike the typical usage of the term "offshore" in the marine industry, offshore wind power includes inshore water areas such as lakes, fjords and sheltered coastal areas, utilizing traditional fixed-bottom wind turbine technologies, as well as deep-water areas utilizing floating wind turbines. A subcategory within offshore wind power can be near shore wind power.



Fig: 4. Wind turbines and electrical substation of Alpha Ventus in the North Sea

Offshore wind power refers to the construction of wind farms in bodies of water to generate electricity from wind. Stronger wind speeds are available offshore compared to on land, so offshore wind power's contribution in terms of electricity supplied is higher and NIMBY opposition to construction is usually much weaker. However, offshore wind farms are relatively expensive at the end of 2012, 1,662 turbines at 55 offshore wind farms across 10 European countries were generating electricity enough to power almost five million households.

V. SYSTEM CONFIGURATION AND CONTROL DESIGN

Fig. 5 shows a diagram of a utility connected industrial system addressed in this paper.

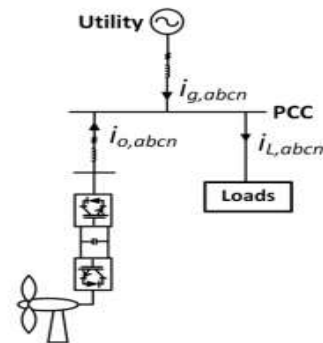

Fig. 5 Single line diagram of the addressed industrial system with wind turbine system.

The structure of the power converter used in the wind turbine system is a back-to-back converter with a permanent magnet synchronous generator (PMSG) connected to the same bus with the loads. The loads are a combination of linear and highly inductive loads causing harmonics at the PCC. The model of the wind turbine system considered in this paper is described. The generator of the system is based on the Permanent Magnet Synchronous Generator (PMSG). The model of the PMSG used in this paper is presented.

5.1. Conservative Power Theory

The Conservative Power Theory, proposed by [11], decomposes the power and current in the stationary frame, according to terms directly related to electrical characteristics, such as average power transfer, reactive energy, unbalanced loads and nonlinearities. Assuming a generic poly-phase circuit under periodic operation (period T), where (v) and (i) are, respectively, the voltage and current vectors, and \hat{v} is the unbiased integral of the voltage vector measured

at a given network port (phase variables are indicated with subscript “m”), the CPT authors define:

Instantaneous active power:

$$p(t) = \underline{v} \cdot \underline{i} = \sum_{m=1}^M v_m i_m \quad (1)$$

Instantaneous reactive energy:

$$w(t) = \underline{\hat{v}} \cdot \underline{i} = \sum_{m=1}^M \hat{v}_m i_m \quad (2)$$

The corresponding average values of eq. (1) and eq. (2) are the active power and reactive energy defined in eq. (3) and eq. (4), respectively as follows:

$$P = \bar{p} = (\underline{v}, \underline{i}) = \frac{1}{T} \int_0^T \underline{v} \cdot \underline{i} dt = \sum_{m=1}^M P_m \quad (3)$$

$$W = \bar{w} = (\underline{\hat{v}}, \underline{i}) = \frac{1}{T} \int_0^T \underline{\hat{v}} \cdot \underline{i} dt = \sum_{m=1}^M W_m \quad (4)$$

The phase currents are decomposed into three current components as follows:

Active phase currents are defined by:

$$i_{am} = \frac{\langle v_m, i_m \rangle}{\|v_m\|^2} v_m = \frac{P_m}{V_m^2} v_m = G_m v_m \quad (5)$$

Where, equivalent phase conductance denoted by G_m .

Reactive phase currents are given by:

$$i_{rm} = \frac{\langle \hat{v}_m, i_m \rangle}{\|\hat{v}_m\|^2} \hat{v}_m = \frac{W_m}{\hat{V}_m^2} \hat{v}_m = B_m \hat{v}_m \quad (6)$$

Where B_m is the equivalent phase reactivity.

Void phase currents are the remaining current items:

$$\underline{i}_{vm} = \underline{i}_m - \underline{i}_{am} - \underline{i}_{rm} \quad (7)$$

Where they convey neither active power nor reactive energy. The active and reactive phase currents can be further decomposed into balanced and unbalanced terms.

The balanced active currents have been defined as:

$$\underline{i}_{am}^b = \frac{\langle v_m, i_m \rangle}{\|v\|^2} v_m = \frac{P}{V^2} v_m = G^b v_m \quad (8)$$

and such currents represent the minimum portion of the phase currents, which could be associated with a balanced equivalent circuit, responsible for conveying the total active power (P) in the circuit, under certain voltage conditions.

VI. CONTROL DESIGN

Machine Side Controller The purpose of the machine side converter is to track the optimum point of the rotor to extract the maximum power existing in the turbine. For a given wind turbine, the maximum power occurs at the maximum power coefficient of the turbine. For a given wind speed there is an optimum rotor speed that gives the optimum tip speed ratio.

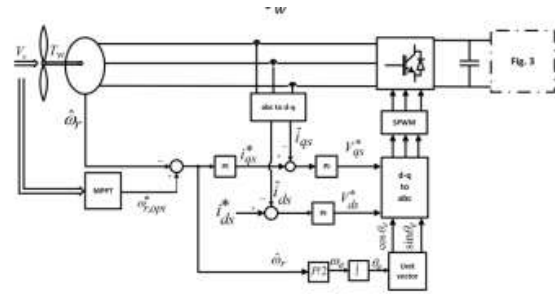

Fig. 6 Control scheme of machine side control

By knowing the tip speed ratio of the wind turbine one can extract the maximum power from the rotor by calculating the optimum rotor speed as:

$$\lambda_{opt} = \frac{R_w \omega_{w,opt}}{v_w} \quad (9)$$

Then, this optimum rotor reference is subtracted from the measured rotor speed to produce the speed error. As shown in Fig. 6, a rotor speed controller is designed to generate the quadrature current reference to the internal current controller. The direct current reference in this paper is set to zero. The detail of the controller design procedure is presented. The parameters and values of the grid side system and the load are illustrated in Table I.

Table I: PMSG parameters and Wind Turbine specifications

Parameters	Values
Stator resistance	0.672 ohm
d-axis leakage inductance	13.74mH
q-axis leakage inductance	13.74mH
Flux linkage	2.39Wb
Number of poles of machines	24
Voltage	500V
Nominal output power of wind turbine	10kW
Base wind speed	10m/s
Base rotor speed	200rps

6.1. Grid Side Controller

In this section the current-controlled voltage source inverter is designed and modeled. The control scheme for the four-leg grid side inverter is shown in Fig. 7.

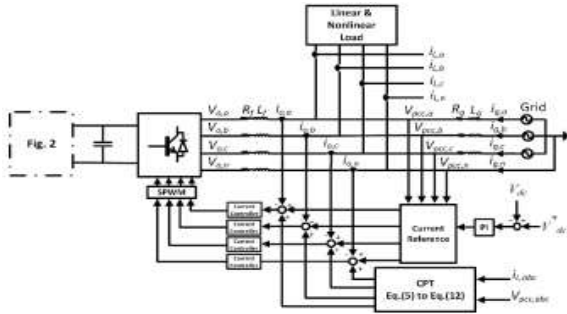

Fig. 7 control scheme of grid side control

Fig. 7 illustrates the schematic diagram of the grid-tied four-leg inverter unit, consisting of a four-leg voltage source converter (VSC) and the network load that are connected to the distribution network at PCC. The inductance of the filter is L_f and R_f is the ohmic loss of the inductor. The machine side converter of Fig. 2 is connected in parallel with the VSC DC-link capacitor C_{dc} . It is shown that the grid side inverter unit is controlled in an abc -reference frame. v_{pcc} is dictated by the grid representing the PCC/load voltage. The control objective is to allow the wind source to inject its available energy, as well as to work as an active power filter for improving power quality based on CPT functionalities. Fig. 8 shows the circuit, containing both balanced and unbalanced linear and non-linear loads.

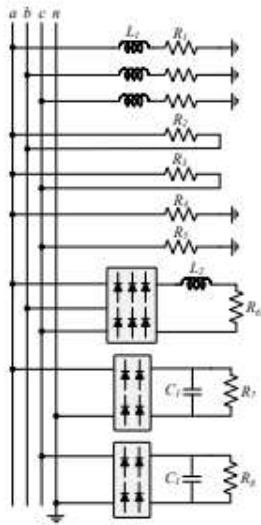

Fig. 8 Configurable load

VII. SIM LINK BLOCK DIAGRAM WITH PID CONTROLLER

The figure shows that the PID Controller as used in the place of PI Controller. The PI Controller is replaced with the PID Controller for the better performance in working and more efficient. By using

the PID Controller we can maintain the rising time and settling time and peak over shoot. The block diagram shows that the voltage and current measurements at the grid side and wind turbine side and load side.

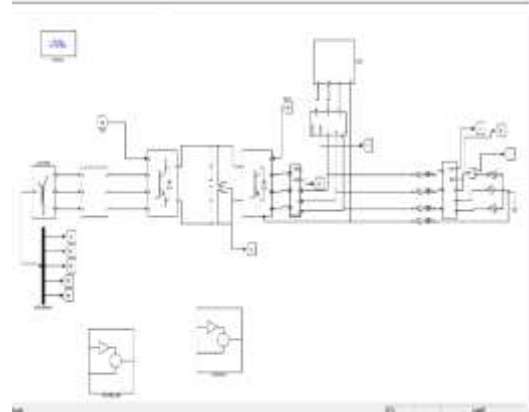

Fig. 9 Simulation diagram

The structure of the power converter used in the wind turbine system is a back to back converter with a permanent magnet synchronous generator connected to the same bus with the loads. The loads are a combination of linear and highly inductive loads.

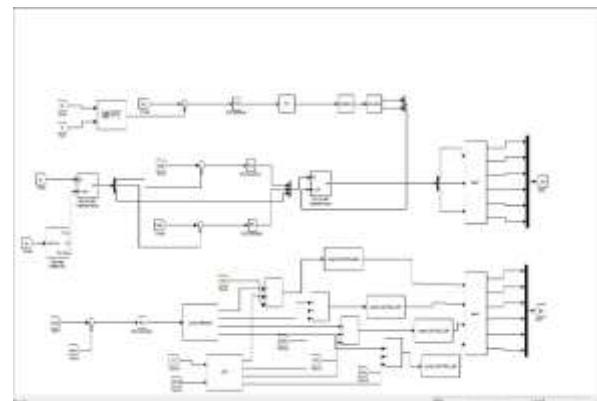

Fig. 10 Control design

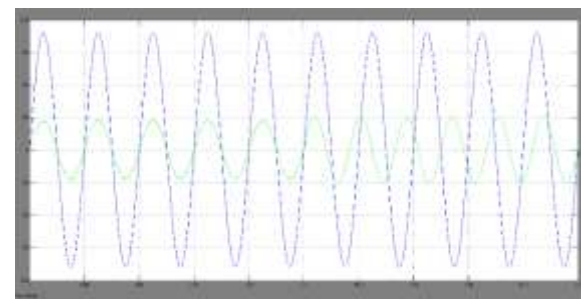

Fig. 11 Active power reactive power delivery pcc voltage and inverter current

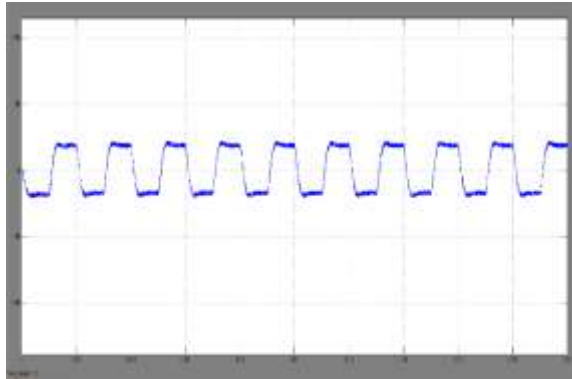

Fig. 12 Grid neutral current and inverter neutral current

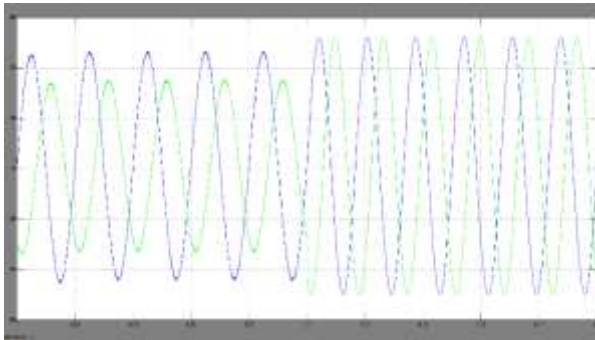

Fig. 13 Two phases of grid currents

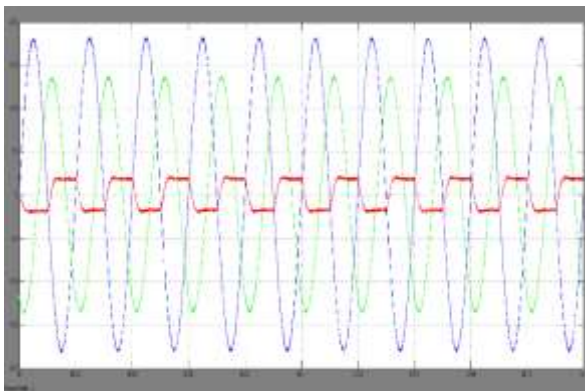

Fig. 14 Active power delivery and non-active compensation

VIII. CONCLUSION

This project addressed a comprehensive control method for a back-to-back wind turbine system connected to an industrial plant with PID controller. The control uses the four-leg inverter at the grid side to supply available active power from the wind turbine system along with full compensation of load current disturbances. The main contribution is based on CPT to impress the set-point reference and impose disturbances mitigation, which adds significant

flexibility to the control structure. The control structure was tested with a comprehensive real-time benchmarking case-study with hardware in the loop. The control algorithms were compiled inside our TI DSP and validated using the real-time system “Opal-RT”. The algorithms were debugged and are ready for experimental validation in a retrofitting of a wind turbine (future work). The results showed good performance of the algorithm and the THD was improved for all different operation conditions. The results support the system presented here which can avoid installation of active filter hardware by the utility or by the industrial consumer.

REFERENCES

- [1] “Global Wind Report Annual Market Update 2013,” 2013. [Online]. Available: <http://www.gwec.net>.
- [2] S. Li, T. A. Haskew, R. P. Swatloski, and W. Gathings, “Optimal and Direct-Current Vector Control of Direct-Driven PMSG Wind Turbines,” *IEEE Trans. Power Electron.*, vol. 27, no. 5, pp. 2325–2337, 2012.
- [3] N. Angela, M. Liserre, R. A. Mastromauro, and A. D. Aquila, “A Survey of Control Issues in PMSG-Based,” *IEEE Trans. Ind. Informatics*, vol. 9, no. 3, pp. 1211–1221, 2013.
- [4] J. Lagorse, M. G. Simões, and A. Miraoui, “A Multiagent Fuzzy-LogicBased Energy Management of Hybrid Systems,” *IEEE Trans. Ind. Appl.*, vol. 45, no. 6, pp. 2123–2129, 2009.
- [5] X. Tan, Q. Li, and H. Wang, “Advances and Trends of Energy Storage Technology in Microgrid,” *Int. J. Electr. Power Energy Syst.*, vol. 44, pp. 179–191, Jan. 2013.
- [6] P. F. Ribeiro, B. K. Johnson, M. L. Crow, A. Arsoy, and Y. Liu, “Energy Storage Systems for Advanced Power Applications,” *Proc. IEEE*, vol. 89, no. 12, pp. 1744–1756, 2001.
- [7] M. G. Simoes, B. K. Bose, and R. J. Spiegel, “Fuzzy Logic Based Intelligent Control of a Variable Speed Cage Machine Wind Generation System,” *IEEE Trans. Power Electron.*, vol. 12, no. 1, pp. 87–95, 1997.
- [8] A. Chauhan and R. P. Saini, “A Review on Integrated Renewable Energy System Based Power Generation for Stand-alone Applications: Configurations, Storage Options, Sizing Methodologies and Control,” *Renew. Sustain. Energy Rev.*, vol. 38, pp. 99–120, Oct. 2014.
- [9] C. N. Bhende, S. Mishra, and S. G. Malla, “Permanent Magnet Synchronous Generator-Based

Standalone Wind Energy Supply System,” IEEE Trans. Sustain. Energy, vol. 2, no. 4, pp. 361–373, 2011.

[10] H. Akagi, E. H. Watanabe, and M. Aredes, Instantaneous Power Theory and Applications to Power Conditioning. 2007.

[11] P. Tenti, H. K. M. Paredes, and P. Mattavelli, “Conservative power theory, a framework to approach control and accountability issues in smart microgrids,” IEEE Trans. Power Electron., vol. 26, no. 3, pp. 664–673, 2011.

[12] A. Mortezaei, M. G. Simoes, and F. P. Marafao, “Cooperative Operation Based Master-Slave in Islanded Microgrid with CPT Current Decomposition,” in Proc. IEEE PES, Denver, Colorado, USA, 2015, pp. 1–5.